

AR 165

May 2025

validated Dutch version

Approval requirement 165

Metal gas meter brackets



**Trust
Quality
Progress**

Foreword Kiwa

This, translated from Dutch, approval requirement (AR), is approved by the Board of Experts (BoE) GASTEC QA. in which relevant parties in the field of gas related products are represented. This Board of Experts supervises the certification activities and where necessary require the GASTEC QA approval requirement to be revised. All references to Board of Experts in this GASTEC QA approval requirement pertain to the above-mentioned Board of Experts.

This, translated from Dutch, AR will be used by Kiwa Nederland BV in conjunction with the GASTEC QA general requirements and the KIWA regulations for certification.

Kiwa has a method which is established in the certification procedure for the execution of:

- The investigation for provisioning and maintaining a GASTEC QA product certificate based on this AR.
- The periodic evaluations of the certified products for the purpose of maintaining a provided GASTEC QA product certificate based on this AR.

This AR, translated from Dutch, is used as supporting document. In case of doubt of interpretation of this AR, the Dutch version is leading.

Kiwa Nederland B.V.

Wilmersdorf 50
P.O. Box 137
7300 AC Apeldoorn
The Netherlands

Tel. +31 88 998 33 93
Fax +31 88 998 34 94
Nl.kiwa.info@kiwa.com
www.kiwa.com/nl/nl/

© 2025 Kiwa Nederland B.V.

All rights reserved. No part of this book may be reproduced, stored in a database or retrieval system, or published, in any form or in any way, electronically, mechanically, by print, photoprint, microfilm or any other means without prior written permission from the publisher.

The use of this approval requirement by third parties, for any purpose whatsoever, is only allowed after a written agreement is made with Kiwa to this end

Contents

Foreword Kiwa		1
Contents	2	
1	Introduction	4
1.1	General	4
1.2	Scope	4
2	Definitions	5
3	Material and product requirements	6
3.1	Composition and use	6
3.1.1	Composition	6
3.1.2	Gas pressure regulator/ low pressure cut-off valve (GGB)	6
3.2	Materials	6
3.2.1	Bracket materials	6
3.2.2	Rubber	6
3.3	Construction	6
3.3.1	Gas valves	6
3.3.2	Wall thickness steal pipes	7
3.3.3	Plug connections	7
3.3.4	Connections	7
3.3.5	Connection points gas meter	8
3.3.6	Pressure test nipple	8
3.3.7	Sealing material for threaded joints	9
3.4	Bendable gas meter connection tubes	9
4	Performance requirements and testmethods	10
4.1	General	10
4.2	Leak tightness	10
4.2.1	Leak tightness of the gas meter bracket	10
4.2.2	Leak tightness of the composed meter bracket	10
4.2.3	Testmethod	10
4.3	Strength of the union couplers	11
4.3.1	Testmethod	11
4.4	Quality of welds, soldered joints, moulded and injection moulded parts	11
4.4.1	Testmethod	11
4.5	Pressure loss	12
4.5.1	Testmethod	12
4.6	Resistance against mounting stress	13
4.6.1	Test method	14
4.7	Resistance against bending load	14

4.7.1	Testmethod	14
4.8	Resistance against vertical load	15
4.8.1	Testmethod	15
4.9	Resistance against impact	16
4.9.1	Testmethod	16
4.10	Resistance against high temperature	16
4.10.1	Test method	16
4.11	Push in coupling	17
4.11.1	Resistance against bending	17
4.11.2	Resistance against rotating of the connection	18
4.11.3	Resistance against tensile load	18
5	Marking, instructions and packaging	19
5.1	Marking	19
5.2	Instructions	19
5.3	Packaging	19
6	Quality system requirements	20
7	Summary of tests	21
7.1	Evaluation matrix	21
8	List of referenced documents and source	22
8.1	Standards / normative documents	22
8.2	Source of informative documents	23

1 Introduction

1.1 General

This GASTEC QA approval requirement (AR) in combination with the GASTEC QA general requirements, is applied by Kiwa as the basis for the issuing and maintaining the GASTEC QA product certificate for metal gas meter brackets.

With this product certificate, the certificate holder can demonstrate to his or her customers that an expert independent organization monitors the production process of the certificate holder, the quality of the product and the related quality assurance.

Next to the requirements established in this AR and the general requirements, Kiwa has additional requirements in the sense of general procedural requirements for certification, as laid down in the internal certification procedures.

This GASTEC QA approval requirement replaces the version of January 2020.

List of changes:

- These approval requirements have been fully reviewed textually.
- Editorial changes
- Change of paragraphs.

The product requirements have not changed.

1.2 Scope

This approval requirement applies to metal gas meter brackets for tension-free mounting of gas meters for use of 1st, 2nd and 3rd family gases in accordance with EN 437.

The gas meter bracket can be provided with a valve on the inlet- and / or outlet connection and a possibility for connecting a pressure regulator / low pressure cut-off valve (GGB). The maximum operating pressure for the part of the gas meter bracket upstream of the domestic pressure regulator is 200 mbar.

2 Definitions

In this approval requirement, the following terms and definitions are applicable:

Board of Experts (BoE): The Board of Experts GASTEC QA.

Inclusions: Material, other than the material intended to produce the product, that is present in the material of the product. Or degradations of the material with which the product is produced that are present in the material.

Maximum operating pressure (MOP): Maximum pressure that a component is capable of withstanding continuously in service under normal operating conditions.

Unacceptable deviations: Deviations in the material that indicate that the material is not of a constant quality, such as discoloration or different structures.

See also the definitions mentioned in the GASTEC QA general requirements.

DRAFT

3 Material and product requirements

This chapter contains the material and product requirements that the raw materials, materials and products used shall meet.

3.1 Composition and use

3.1.1 *Composition*

The composition, dimensions and tolerances of the gas meter bracket parts and the welded seams shall correspond with the construction drawings of the manufacturer. These drawings shall be part of the certification report and shall be used during product verification tests.

3.1.2 *Gas pressure regulator/ low pressure cut-off valve (GGB)*

In case the manufacturer supplies a gas pressure regulator or low-pressure cut-off valve (GGB) with the gas meter bracket, this regulator shall comply with the requirements of approval requirement 11. The connection used shall comply with approval requirement 11 as well. The manufacturer shall provide an auxiliary construction to replace the gas pressure regulator. This will be used with the test for pressure loss and the determination of the leak tightness of the composed product.

3.2 Materials

3.2.1 *Bracket materials*

Gas carrying and bearing parts of the gas meter brackets shall be produced from a, for the purpose, suitable quality metal. The material shall be in- and externally clean and free of inclusions, cavities, cracks or other unacceptable deviations which can influence the functional characteristics of the gas meter bracket. The melting temperature of gas carrying and bearing parts shall be higher than 425°C.

3.2.2 *Rubber*

Rubber components shall comply with EN 549 with a quality of minimal Class A2/H3 or EN 682, type GAL or GBL.

3.3 Construction

3.3.1 *Gas valves*

Gas meter brackets can be provided on the inlet- and / or outlet with a valve.

Valves as part of the gas meter bracket shall comply with approval requirement 69 "Metal connection valves and Laboratory valves for gas installations in houses and buildings" or with approval requirement 69-1 "Manually operated ball valves and closed bottom taper plug valves for gas installations for buildings" with the exception on the connections.

The connections shall comply with clause 3.3.4 of this approval requirement. The valve on the inlet- and/ or outlet of the gas meter bracket can also be provided with a click / plug-in connection as connection between the gas meter bracket and valve, or in the production process inseparable produced with the gas meter bracket.

3.3.2 Wall thickness steel pipes

The wall thickness of steel pipes upon which on the inlet- and outlet gas sealing thread according to EN 10226-1 is cut, shall comply with approval requirement 15 "Steel pipes for welding or threading".

3.3.3 Plug connections

In case that the gas meter bracket is applied with plug in connections and/ or blind stops, these shall be carried out in such a way that after plugging in the coupling, the connection cannot be dis-assembled without damaging the parts. It shall be possible to control either physically or visually if the blind stop is assembled in a correct way.

3.3.4 Connections

It is allowed to provide the gas meter bracket, ex works, at the inlet- and outlet side with one of the following connection options:

- 1) Sealing gas thread according to EN 10226-1.
- 2) Compression fittings for connecting copper pipes according to approval requirement 35.
- 3) Plumbing fittings with ends for capillary soldering, capillary brazing and/ or threaded connections according to approval requirement 6.
- 4) Press fittings according to approval requirement 186.
- 5) Bendable gas meter connection tubes according to approval requirement 7, see also paragraph 3.4.
- 6) The dimensions of the 3-part coupling according to NEN 2541, NEN 2542, NEN 2544. The rubber sealing gasket according to NEN 2545 with a rubber quality according to EN 549 class A2/H3.
- 7) Insulation couplings according to approval requirement 154.
- 8) Fittings for multi-layer pipe according to approval requirement 198.
- 9) Manually operated ball valves or closed bottom taper plug valves according to paragraph 3.3.1, possibly provided with a plug-in connection.
- 10) Plug connections with on one side one of the before mentioned connection options.

It also allowed to provide the gas meter bracket, ex works, on the inlet side with the following connection option:

1. Tensile resistant fitting for PE pipes according approval requirement 70.

Contrary to the requirements for rubber in approval requirement 70, the rubber parts in this fitting can also comply with the quality according to EN 549 class A2/H3.

If the union nut is secured behind the point piece in a different way as described in NEN 2542 and NEN 2544, the dimensions as mentioned in NEN 2542 shall be maintained for the point piece.

Dimension "e" shall have at least the length according to NEN 2542.

The dimensions for the union nut shall comply with NEN 2544, whereby the height "p" shall be at least the length according to NEN 2544 and the screw thread shall comply with ISO 228-1.

After applying the rubber gasket to the point piece, it shall be possible to turn the union nut over a length of $\frac{3}{4} \times l$ over the thread (l) of the tap connection (figure 1).

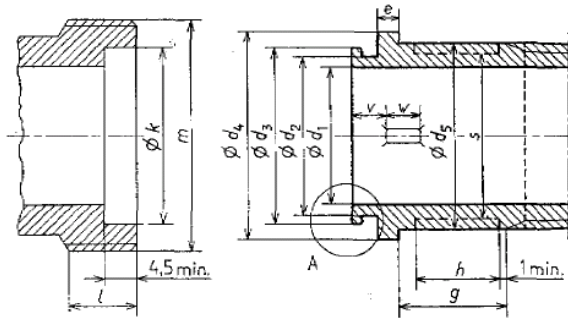

Figure 1: Valve connection

3.3.5 Connection points gas meter

The dimensions of the connection for the gas meter shall comply with NPR 7028. Contrary to NPR 7028 the tolerances of the heart-to-heart size of the connection points of the gas meter bracket shall be ± 0.3 mm for all dimensions.

Contrary to NPR 7028 the union nut can be secured in another way behind the point piece. In that case the dimensions of the dimensions as pointed out in NPR 7028 shall be followed for the point piece and union nut. In addition to the NPR 7028, after applying the rubber gasket on the point piece, it shall be possible to turn the union nut over a length $\frac{3}{4} \times l$ over the thread (l) of the tap connection (figure 2).

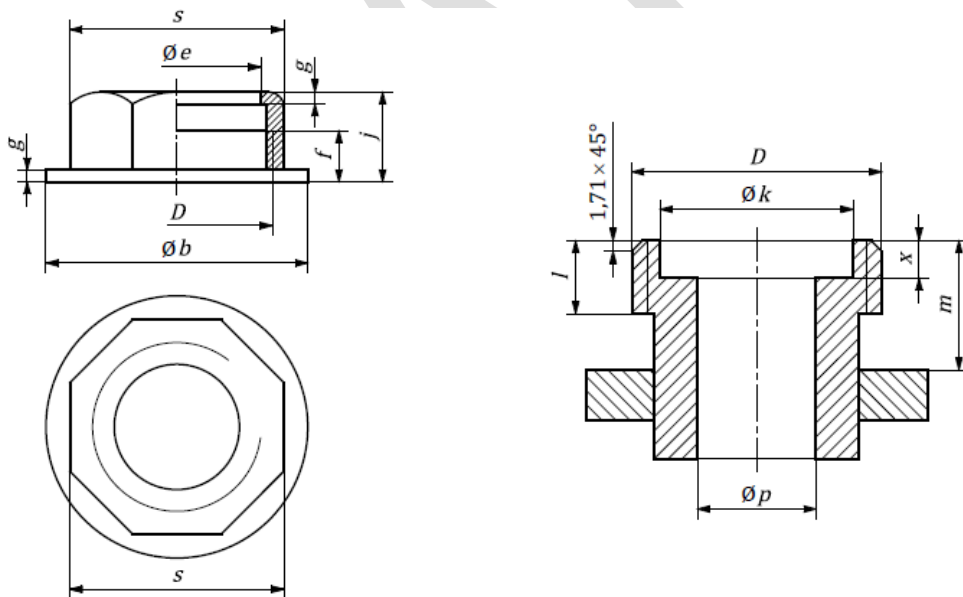

Figure 2: gas meter part

For the G10, G16 and G25 meter brackets the connection for the gas meter shall comply with DIN 3376-1 Gaszählerverschraubungen – Teil 1: Zweistutzenanschluss; Technische Regel des DVGW. Coaxial connections shall comply with EN 1359.

3.3.6 Pressure test nipple

At least one pressure test nipple shall be present on the outlet of the gas meter bracket. The pressure test nipple shall comply with NEN 1571.

3.3.7 Sealing material for threaded joints

The sealing material for threaded joints used for the inseparable connection of parts or components shall comply with EN 751 part 1, EN 751 part 2 or EN 751 part 3, "Sealing material for metallic threaded joints in contact with 1st, 2nd and 3rd family gases and hot water".

3.4 Bendable gas meter connection tubes

The bendable gas meter connection tubes shall comply with approval requirement 7 except for the requirements for connections and pressure loss.

DRAFT

4 Performance requirements and test methods

This chapter contains the performance requirements and associated test methods that the products shall meet. This chapter also specifies the limit values, if applicable.

4.1 General

All tests are carried out at 23 ± 5 °C. The measured values for leak tightness and pressure loss are converted to 15 °C and 1013.25 mbar absolute.

Pressures shall be measured with a precision manometer according to EN 837-2.

Tests are carried out in triplicate, except for paragraph 4.5, this is only carried out in singular.

4.2 Leak tightness

4.2.1 *Leak tightness of the gas meter bracket*

With a composed gas meter bracket at least every gas carrying channel shall be tested separately on leak tightness. Gas meter brackets with a flange for a pressure regulator or for coaxial connections for the gas meter, the individual channels shall be sealed with a blind flange. The leak tightness shall be less than or equal to 20 cm³ s / hour at both a test pressure of 300 mbar and a test pressure of 6 mbar.

4.2.1.1 *Test method*

Close off all channels of the gas meter bracket with the appropriate blind flanges, blind plugs and other aids. Connect the gas meter bracket to the test equipment and test according to the provided pressures.

4.2.2 *Leak tightness of the composed meter bracket*

When testing the complete gas meter bracket (gas meter bracket including plug-in connection, blind stop and overflow cap), the leakage density shall be less than or equal to 20 cm³ s / hour at both a test pressure of 300 mbar and a test pressure of 6 mbar.

If the gas meter bracket is equipped with integrated ball or plug valves or valves with a plug-in connection, the leak tests shall be carried out with the tap in the half open position.

4.2.2.1 *Test method*

Assemble the meter bracket according to the manufacturer's instructions and connect to the test equipment and test according to specified pressures for 400 seconds per test pressure.

4.3 Strength of the union couplers

It shall be possible to tighten the union nut with a torque according to table 1 without distortion or damage occurring. The applied moment shall be maintained for 10 s. The gas meter bracket shall be leak tight after releasing the strength load according to clause 4.2.2.

Gas meter connection size D union nut	Tightening moment in Nm
GM $\frac{3}{4}$ (DN 20)	70
GM 1 (DN 25)	87,5
GM 1 $\frac{1}{2}$ (DN 40)	140
Gas point pieces size m union nut	
G $\frac{1}{2}$ " (DN 12)	20
G $\frac{3}{4}$ " (DN 15)	30
G 1" (DN 20)	40
G 1 $\frac{1}{4}$ " (DN 25)	55
G 1 $\frac{1}{2}$ " (DN 32)	80
G 2" (DN 40)	100

Table 1: tightening moments strength of union couplers

If a structure is used to secure the union nut behind the point piece, other than specified in NEN 2542 and NEN 2544, an additional test shall be carried out. The union nut shall then be tightened with a torque of 6 Nm x DN for 10 seconds. The union nut shall not come loose from the point piece.

4.3.1 Test method

Attach the point piece to the test equipment using the union nut with a torque according to Table 1. Maintain this torque for 10 seconds. Remove the tightening torque and determine the leak tightness according to section 4.2.2.

4.4 Quality of welds, soldered joints, moulded and injection moulded parts

Gas meter brackets with factory welds and solder connections or similar cylindrical connections such as press and glue connections in gas-carrying parts of the bracket shall be able to withstand an internal water pressure of 16 + 1 / -0 bar for at least 15 minutes. The welds and / or soldered joints shall not show any leaks or forms of damage.

Gas meter brackets with casting or kneaded parts shall be able to withstand an internal air pressure of 1 bar for at least 15 minutes and, due to porosity, shall not show any visible leakage through the wall when soaking with a leak detection agent.

4.4.1 Test method

Close all channels of the meter bracket with suitable blind flanges, blind plugs and other aids. Connect the meter bracket to the test equipment and test according to the specified pressure and time.

4.5 Pressure loss

The pressure loss measured over the inlet side until the outlet side of the gas meter bracket, including the provided connection aids and possible integrated valves, shall not exceed the value as provided by the manufacturer. The pressure loss shall be measured with a flow according to table 2.

The test shall be carried out with air at a pressure of 25 mbar. The manufacturer shall provide a standard aid construction to replace the pressure regulator. The test is carried out with the aid construction.

For gas meter:	flow in m ³ s/h air
G 2,5	3.2
G 4	4.8
G 6	8.0
G 10	12.8
G 16	20.0
G 25	32.0

Table 2: minimum flow for gas meter brackets

4.5.1 Test method

Connect the gas meter bracket, with a fully opened gas valve if present, to the measuring device according to figure 3. With the help of the control valve (9), set a flow according to table 2 at an outlet pressure of 25 mbar.

If the gas meter bracket is provided with a bendable gas meter connection tube according to paragraph 3.4, it shall be bent at an angle of 90 ° with a radius as stated in the test "Pressure loss" of approval requirement 7. Measure the pressure difference with the differential manometer (4).

Carry out the following measurements:

- 1) Measure the pressure loss from the gas meter bracket inlet to the gas meter inlet = P1
- 2) Install a short-circuit tube between the gas meter connections on the gas meter bracket. Measure the pressure loss from the inlet gas meter bracket to the outlet of the short-circuit tube = P2
- 3) Measure the pressure loss from the gas meter bracket inlet to the gas meter bracket outlet = P3

Calculate the pressure loss of the gas meter bracket from the measured values.

$P_{\text{total}} = P3 - (P2 - P1)$

Round the measured pressure loss to 0.1 mbar.

Reduce the air flow rate indicated by the volume flow meter (8) to standard conditions according to:

$$V_{st} = V \cdot \frac{P + P_a}{1013} \cdot \frac{288}{273 + T}$$

In which;

- V_{st} is the air flow under standard circumstances, in m³/h;
- V is the air flow during measurement, in m³/h;
- P_a is the atmospheric pressure (absolute pressure), in mbar;
- P is the test pressure (overpressure), in mbar;
- T is the air temperature, in °C.

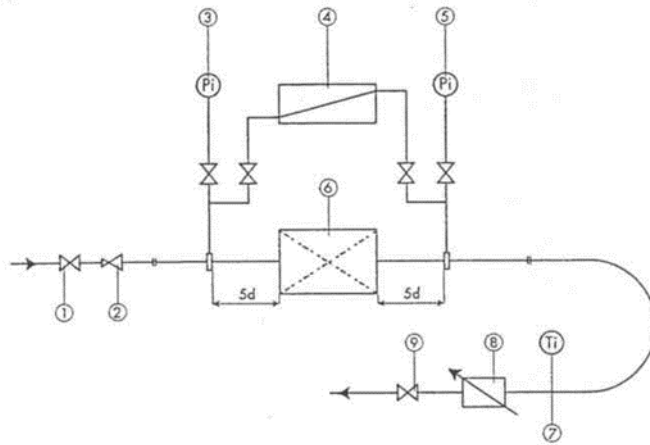

Figure 3

1 = Valve	Nominal inlet DN	Inner centerline of the measurement pipe (D) (mm)
2 = Pressure regulator inlet pressure		
3 = Manometer inlet pressure	10 (3/8")	13
4 = Differential manometer	15 (1/2")	16
5 = Manometer outlet pressure	20 (3/4")	22
6 = Meter bracket under test connected to measurement pipes, D see table	25 (1")	28
7 = Temperature meter	32 (1 1/4")	35
8 = Flow meter	40 (1 1/2")	41
9 = Valve regulator	50 (2")	52

Legend figure 3

4.6 Resistance against mounting stress

Brackets fitted with a sealing gas thread shall be able to withstand a torsional load on these connections according to the table below. After this test, the gas meter bracket shall be leak tight according to section 4.2.2 and shall not show any permanent deformation that influences the functional characteristics of the gas meter bracket.

DN Thread connection	Torsional load (Nm)
20 (3/4")	100
25 (1")	125
32 (1 1/4")	160
40 (1 1/2")	200
50 (2")	250

Table 3: Torsional load on gas meter bracket connections

4.6.1 Test method

- 1) Mount the gas meter bracket with the appropriate mounting points on a test bench.
- 2) Screw a threaded pipe or threaded sock with sealing thread packing (tape) onto the connections of the gas meter bracket.
- 3) Apply a moment to the threaded pipe or threaded socks for 10 seconds with an accuracy of 5% Rdg, according to table 3.
- 4) Remove the moment after 10 seconds.
- 5) Next, test the construction for leak tightness according to paragraph 4.2.2.
- 6) The dimensions of the bracket shall be checked for permanent deformation.

4.7 Resistance against bending load

The gas meter bracket shall be able to withstand a horizontal load of 400 N engaging the center of the gas meter. After this test, the gas meter shall be leak tight according to paragraph 4.2.2 and shall not show any permanent deformation that is greater than 5 mm in relation to the starting position. The gas meter bracket shall not come loose from the wall bracket.

4.7.1 Test method

- 1) Mount the gas meter bracket with the intended mounting points or the intended mounting bracket on a test bench. If the gas meter bracket is equipped with an adjustable mounting bracket, this shall be set so that the distance from the center of the meter connection to the wall is the greatest.
- 2) Mount a suitable U-shaped bracket on the gas meter connection points. The center size of the bracket shall be adjusted to the connection size of the gas meter. The height of the bracket shall comply with table 4. Measure the distance from center to wall.
- 3) Apply a force (F) of 400 ± 10 N to the underside of the U-bracket for 30 seconds (see figure 4).
- 4) Release the force after 30 seconds.
- 5) Next, test the construction for leak tightness according to paragraph 4.2.2.
- 6) The dimensions of the bracket shall be checked for permanent deformation. To do this, measure the distance from the center of the bracket to the wall. This may not deviate more than 5 mm from the starting position.

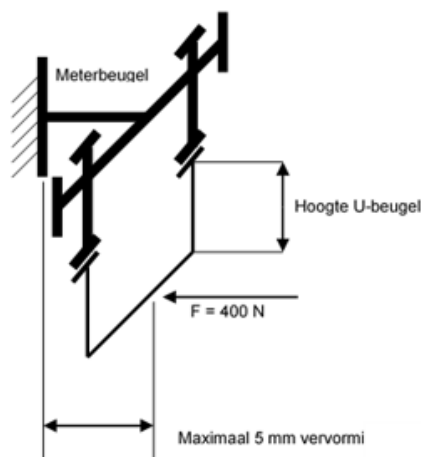

Figure 4

Gasmeter type	Height of the U-bracket (mm)
G2,5	150
G4	150
G6	180
G10	230
G16	230
G25	250

Table 4: Dimension U-bracket

4.8 Resistance against vertical load

The gas meter bracket, including wall bracket, shall be able to withstand a vertical load of 700 N, gripping right in the middle of the top of the gas meter. After this test, the gas meter bracket shall be leak tight according to paragraph 4.2.2 and shall not show any permanent deformation that is larger than 5 mm at the location of the underside of the mounted U-bracket relative to the starting position. The gas meter bracket shall not come loose from the wall bracket.

4.8.1 Test method

- 1) Mount the gas meter bracket with the appropriate mounting points on a test bench. If the gas meter bracket is equipped with an adjustable mounting bracket, this shall be set so that the distance from the center of the meter connection to the wall is the greatest.
- 2) Mount a suitable U-shaped bracket on the gas meter connection points. The heart size of the U-bracket shall be adjusted to the connection size of the gas meter. The height of the U-bracket must comply with table 4. Measure the distance from the center of the bottom of the U-bracket to the wall and the distance from the center of the bottom of the U-bracket to the floor.
- 3) Apply a force (F) of 700 ± 10 N to the top of the horizontal beam of the U-bracket for 30 seconds (see figure 5).
- 4) Release the load after 30 seconds.
- 5) The dimensions of the bracket shall be checked for permanent deformation. To do this, measure the distance from the center of the bottom of the U-bracket to the wall, and the distance from the center of the bottom of the U-bracket to the floor. This may not deviate more than 5 mm from the starting position.
- 6) Next, test the construction for leak tightness according to paragraph 4.2.2.

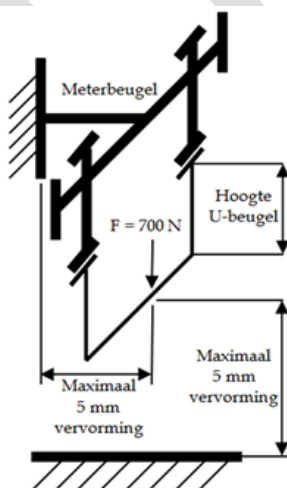

Figure 5

4.9 Resistance against impact

The gas meter bracket shall be able to withstand a horizontal impact, perpendicular to the center of the front face of the gas meter, equal to a fall mass of 2500 grams with a radius of 10 mm \pm 0.5 mm, falling from a height of 2000 mm. The drop body shall be spherical at the bottom. After this test, the gas meter bracket shall be leak tight according to paragraph 4.2.2. The gas meter bracket shall not come loose from the wall bracket.

4.9.1 Test method

- 1) Mount a suitable U-shaped bracket on the gas meter connection points. The center size of the bracket shall be adjusted to the connection size of the gas meter. The height of the bracket shall comply with table 4. Optionally, a gas pressure regulator shall be mounted. If the gas meter bracket is equipped with an adjustable mounting bracket, this shall be set so that the distance from the center of the meter connection to the wall is smallest.
- 2) Mount the gas meter bracket in the prescribed manner using the designated mounting points under a fall test device.
- 3) The gas meter bracket is hereby positioned such that the falling weight hits the U-shaped bracket in a manner that corresponds to an impact load directed horizontally on the front face of the gas meter.
- 4) From a height of 2000 \pm 1 mm, drop a weight of 2500 \pm 5 grams onto the center of the U-bracket (See figure 6).
- 5) Next, test the construction for leak tightness according to paragraph 4.2.2.

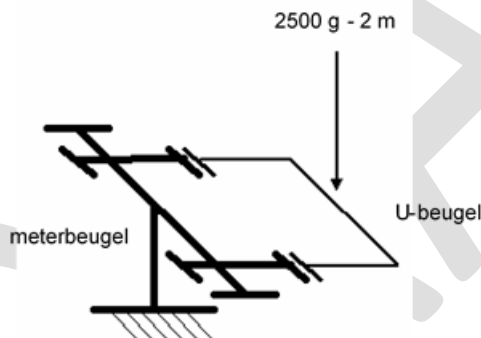

Figure 6

4.10 Resistance against high temperature

After a minimum of 6 hours in the oven at a temperature of 425 + 5 / -0°C, the external metal parts that are subjected to gas pressure shall not have melted or deformed. Blisters may indicate air inclusions and are not permitted.

4.10.1 Test method

Place the complete gas meter bracket (gas meter bracket including plug-in connection, blind plug and overflow cap) in a preheated oven. Wait until the temperature has stabilized again. The gas meter bracket shall be placed for at least 6 hours in an oven in which a temperature of 425 + 5 / -0°C prevails. Check that the external metal parts that are subjected to gas pressure have not melted or deformed. Blisters may indicate air inclusions and are not permitted.

4.11 Push in coupling

In case the gas meter bracket is provided with push in connections, these shall comply with the following requirements.

4.11.1 Resistance against bending

The plug-in connection between gas valve and gas meter bracket shall be able to withstand a bending load MF1 and MF2 according to table 5. During the load and after the load has been removed, the plug-in connection shall not show any permanent deformation and / or damage. The gas meter bracket shall be leak tight after this test in accordance with paragraph 4.2.2.

4.11.1.1 Test method

- 1) Mount the gas meter bracket with the appropriate mounting points (without mounting bracket) on a test bench.
- 2) Mount a steel pipe to the plug-in connection (straight and / or right-angled) or the gas valve mounted on it.
- 3) Apply a force to the end of the steel pipe gradually until the moment MF1 from table 5 ($\pm 5\%$) is reached and hold this moment for 10 ± 3 seconds.
- 4) Repeat this test with an angled plug-in connection with the force MF1 in the other direction (see figure 7).
- 5) Remove the load.
- 6) Then gradually apply a force to the end of the steel pipe so that the moment MF2 from table 5 ($\pm 5\%$) is reached and hold this moment for 900 ± 5 seconds. During this load, check the plug-in connection for external leakage with an internal air pressure for a minimum of 400 seconds of 6 mbar and then for a minimum of 400 seconds with an internal air pressure of 300 mbar. The leakage rate shall not exceed $20 \text{ cm}^3 \text{ s} / \text{hour}$.
- 7) Repeat this test with the force MF2 (table 5) in the other direction (see figure 7).
- 8) Remove the load.
- 9) Check the plug-in connection for permanent deformation and / or damage.

DN	MF 1 in Nm	MF2 in Nm
20	125	40
25	200	50
32	250	64
40	300	80
50	450	100

Table 5: Bending load plug in connection combined with gas meter bracket I

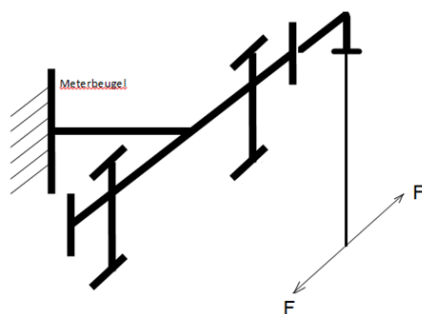

Figure 7 (only drawing of straight version)

4.11.2 Resistance against rotating of the connection

If a plug-in connection allows a rotation, it shall be tested. The plug-in connection shall be able to withstand 2500 ± 10 cycles with an angular rotation of $90 \pm 5^\circ$. The gas meter bracket shall be leak tight after this test in accordance with paragraph 4.2.2.

4.11.2.1 Test method

- 1) Mount the gas meter bracket tested in paragraph 4.11.1 with the appropriate mounting points on a test bench.
- 2) Turn the plug-in connection in the gas meter bracket at a speed of 5 ± 1 cycles per minute. During the test, check the plug-in connection for external leakage with an internal air pressure for a minimum of 400 seconds of 6 mbar and then for a minimum of 400 seconds with an internal air pressure of 300 mbar. The leakage rate shall not exceed $20 \text{ cm}^3 \text{ s} / \text{hour}$.
- 3) The gas meter bracket shall be leak tight after this test in accordance with paragraph 4.2.2.

4.11.3 Resistance against tensile load

The plug-in connection shall be able to withstand a tensile load of 700 N for 60 seconds. During the load and after the load has been removed, the plug-in connection shall not show any deformation and/ or damage. The gas meter bracket shall be leak tight after this test in accordance with paragraph 4.2.2.

4.11.3.1 Test method

- 1) Mount the gas meter bracket tested in section 4.11.2 with the appropriate mounting points on a test bench.
- 2) Gradually load the plug-in connection with a tensile force in the axial direction of $700 -0 / +20 \text{ N}$ and maintain this tensile force for 60 ± 5 seconds.
- 3) Check the plug-in connection during this load for external leakage with an internal air pressure for a minimum of 400 seconds of 6 mbar and then for a minimum of 400 seconds with an internal air pressure of 300 mbar. The leakage rate shall not exceed $20 \text{ cm}^3 / \text{hour}$.
- 4) The gas meter bracket shall be leak tight after this test in accordance with paragraph 4.2.2.
- 5) Check the plug-in connection for permanent deformation and / or damage.

5 Marking, instructions and packaging

5.1 Marking

On the gas meter bracket the following information shall be durably applied:

- GASTEC QA word, logo or punch mark
- Name manufacturer or trademark
- Nominal connection size of the gas meter
- Maximum operating pressure 200 mbar
- Production code and assembly date by month and year (mmyy)

5.2 Instructions

The supplier shall provide user instructions in the Dutch language and in the language of the country in which the product will be used. These instructions shall have the following information included:

- Mounting of the bracket itself.
- Connection of the connecting pipe and inner pipe.
- Mounting of the gas meter and pressure regulator.
- For which type of pressure regulator the construction is suitable.
- The pressure loss of the total construction, as presented for testing, measured in paragraph 4.5.
- If a bendable gas meter connection tube is used, it shall be installed in accordance with the manufacturer's instructions.

5.3 Packaging

The product shall be packed in such a way that external contamination and damage are not possible.

6 Quality system requirements

The requirements for the quality system are described in the GASTEC QA general requirements. An important part of this are the requirements for drawing up a risk analysis (e.g., an FMEA) of the product design and the production process in accordance with chapters 3.1.1.1 and 3.1.2.1. This risk analysis shall be available for inspection by Kiwa.

DRAFT

7 Summary of tests

This chapter contains a summary of tests to be carried out during:

- The initial product assessment;
- The periodic product verification;

7.1 Evaluation matrix

Description of requirement	Clause	Test within the scope of		
		Initial product assessment	Product verification Verification	Frequency
Composition and use	3.1	X	X	Once a year
Materials	3.2	X	X	Once a year
Construction	3.3	X	X	Once a year
Bendable gas meter connection tube	3.4	X		
Leak tightness	4.2			
Leak tightness of the gas meter bracket	4.2.1	X	X	Once a year
Leak tightness of the composed meter bracket	4.2.2	X	X	Once a year
Strength of the union couplers	4.3	X	X	Once a year
Quality of welds, soldered joints, moulded and injection moulded parts	4.4	X	X	Once a year
Pressure loss	4.5	X		
Resistance against mounting stress	4.6	X		
Resistance against bending load	4.7	X		
Resistance against vertical load	4.8	X		
Resistance against impact	4.9	X	X	Once a year
Resistance against high temperature	4.10	X		
Push-in connections	4.11	X		
Resistance against bending load	4.11.1	X		
Resistance against rotating of the connection	4.11.2	X		
Resistance against tensile load	4.11.3	X	X	Once a year
Marking	5.1	X	X	Once a year
Documentation	5.2	X	X	Once a year
Packaging	5.3	X		

8 List of referenced documents and source

8.1 Standards / normative documents

All normative references in this Approval Requirement refer to the editions of the standards as mentioned in the list below.

ISO 228-1: 2003	Pipe threads where pressure-tight joints are not made on the threads - Part 1: Dimensions, tolerances and designation
EN 549: 2019 +A2: 2024	Rubber materials for seals and diaphragms for gas appliances and gas equipment
EN 682: 2002	Elastomeric seals - Materials requirements for seals used in pipes and fittings carrying gas and hydrocarbon fluids
EN 751-1: 1997	Sealing materials for metallic threaded joints in contact with 1 st , 2 nd and 3 rd family gases and hot water -part 1: anaerobic jointing compounds
EN 751-2: 1997	Sealing materials for metallic threaded joints in contact with 1 st , 2 nd and 3 rd family gases and hot water -part 2: non-hardening jointing compounds
EN 751-3: 2022 + A1: 2024	Sealing materials for metallic threaded joints in contact with 1 st , 2 nd and 3 rd family gases and hot water -part 3: unsintered PTFE tapes
EN 837-2: 1997	Pressure gauges - Part 2: Selection and installation recommendations for pressure gauges
EN 1359: 2017	Gas meters – Diaphragm gas meters
EN 10226-1: 2004	Pipe threads where tight joints are made on the threads
NEN 1571: 1967	Pressure test nipples for gas
NEN 1273: 1967	Push-on ends and hose adapters for gas
NEN 2541:1967	Fittings for soldering for gas conduits
NEN 2542:1967	Fittings and connections with outside thread for gas conduits
NEN 2544: 1967	Coupling nuts for fittings for gas and water conduits
NEN 2545: 1967	Packing rings for fittings for gas conduits
NEN 7244-10:2021	Gas supply systems - Pipelines for maximum operating pressure up to and including 16 bar - Part 10: Specific functional requirements for housing for installations and housing for meters with a maximum inlet pressure of 100 mbar and a maximum design capacity of 650 m ⁿ ³/h

NPR 7028: 2022	Gasmeters – Dimensions and connections
DIN 3376 Teil 1:2005	Gaszählerverschraubungen - Teil 1: Zweistutzenanschluss
GASTEC QA approval requirement 6	Plumbing fittings with ends for capillary soldering, capillary brazing and/ or threaded connections
GASTEC QA approval requirement 7	Bendable gas meter connection tubes
GASTEC QA approval requirement 11	Gas pressure regulators, gas leak protectors and combination regulators
GASTEC QA approval requirement 15	Steel pipes for welding or threading
GASTEC QA approval requirement 35	Compression fittings for joining copper pipes
GASTEC QA approval requirement 69-1	Manually operated ball valves and closed bottom taper plug valves for gas installations for buildings
GASTEC QA approval requirement 70	Mechanical fittings for plastic piping systems
GASTEC QA approval requirement 154	Insulation union couplings in gas conduits
GASTEC QA approval requirement 186	Press fittings for joining copper pipes
GASTEC QA approval requirement 198	Multilayer piping systems for indoor gas installations

8.2 Source of informative documents

EN 437: 2021	Test gases- test pressure – appliance categories
GASTEC QA General Requirements	